



ScuL-Sense™ Two-Wire Optic Sensor

Liquid Level Sensor for Tank Truck Overfill Prevention

Featuring Dynacheck® – Automatic and Continuous Self-Checking Circuitry



DESCRIPTION

Scully two-wire optic sensors are purpose-built for liquid petroleum product overfill prevention and point level detection.

They are designed to be used with the Scully Intellitrol®, Intellitrol®2, and ST-15 series loading rack control monitors. The sensors can also be used with the Scully Intellicheck® Monitor series. There is no waiting for the control monitors' permit light to go on because the sensor requires no warm up time. Overfill prevention applications include road tankers, rail cars and storage tanks.

The two-wire optic sensor is a critical component in Scully's unique and patented Dynacheck® circuit design. When used in conjunction with Scully

electronic monitoring equipment, our overfill protection sensor will provide consistent failsafe monitoring. By constantly checking a "closed loop" pulsing signal across the entire system, Scully ensures a safe and reliable loading operation. If rising fuel contacts the sensor, this signal is interrupted and the controlling pumps and valves are shutdown. No operator involvement is needed to end the loading operation.

Scully offers a 5-year warranty on these models of overfill prevention sensors for fixed tank trailer and storage tank applications. Scully sensors have the longest running safety record in the industry and are manufactured in Scully's U.S. factory, which prides itself on its strict quality and safety standards.

2-Wire Sensor

The ScuL-Sense™ design is API compliant and withstands temperature related stresses, dramatically improving reliability across a wide operating range.



IEC 61508 SIL 3 Capable

$\lambda_{DU}=2.0 \text{ FIT}^*$ $\lambda_{SU}=110 \text{ FIT}^*$

*FIT = Failure In Time (1×10^{-9} failures per hour)

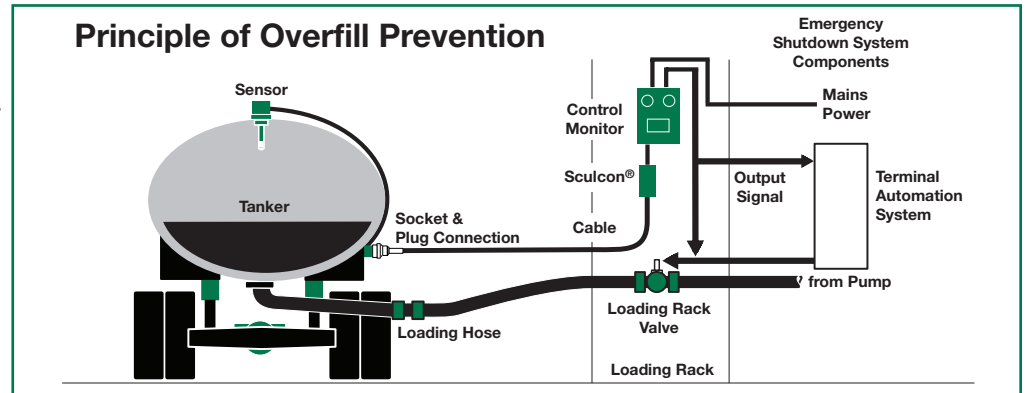

FEATURES AND BENEFITS

- Maximum safety with Dynacheck®— Automatic and continuous self-checking circuitry when used with Scully electronic rack and vehicle onboard monitoring systems.
- Scully's field-proven electro-optics technology.
- Wide temperature range.
- Adjustable Sensing Level.
- Instant-On™— Instant permissive signal. No warmup time required.
- Quick purging of liquid— "fast" repermit as product level drops below the sensing point.
- FM approvals for Class I, Division 1, Groups C and D hazardous locations in the US and Canada.
- Meets requirements of API Recommended Practice RP-1004.



Liquid Level Sensor for Tank Truck Overfill Prevention

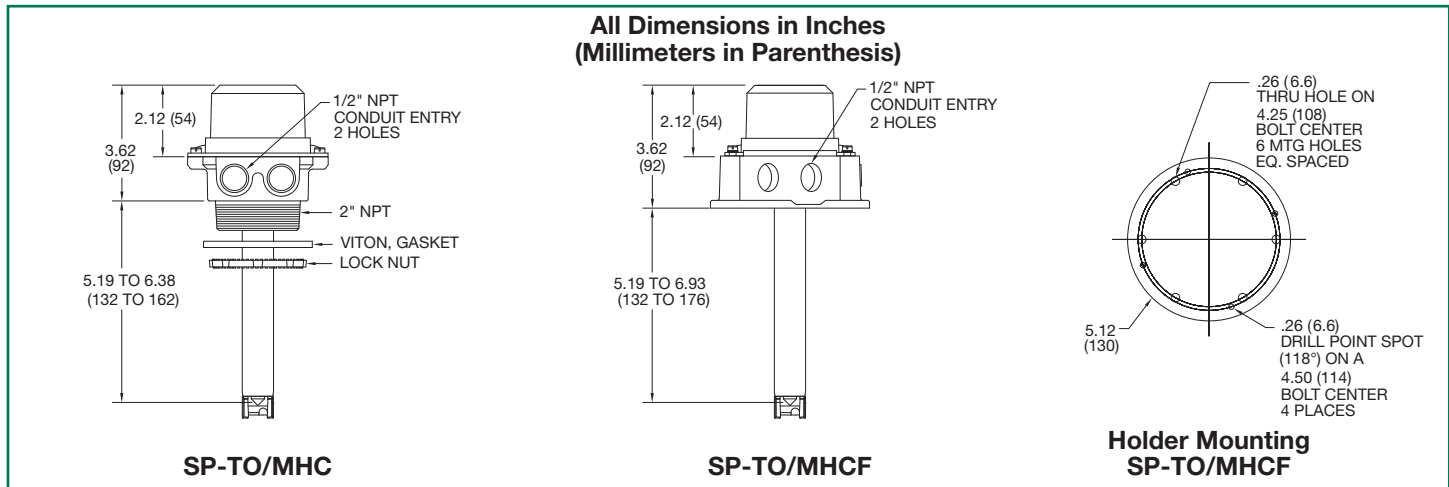

TECHNICAL SPECIFICATIONS

Operating Temp. Range: -40°F to +140°F.
(-40°C to +60°C).

Petroleum Product Range: Gasoline blends & light fuel oils.

Exposed Materials: Aluminum, zinc, borosilicate (Pyrex®) glass, epoxy, conductive nylon and Viton® seals.

Level Repeatability: ±1/16" (±1 mm).

Electrical Leads: 18" (45cm) long, 22 AWG (0.33 mm²).

Cable Entry: Two holes, 1/2" NPT threads.

Detection Level and Size: The detection level is adjustable, refer to sensor outline drawing above, shown for 7" shaft length.

Approvals: The sensor is intrinsically safe for mounting in Class I, Division 1, Groups C & D Hazardous location in accordance with Scully Control Unit approval ratings.

SIL Capable



ORDERING INFORMATION

| Model | Description | Shaft Length | Part Number |
|----------------|--|--------------|-------------|
| SP-TO/MHC(MC) | Two-Wire Optic Sensor, 2" NPT holder, 2 1/8" Medium Cap | 7" (175mm) | 09408L1 |
| | | 12" (300mm) | 09413L1 |
| | | 15" (375mm) | 09416L1 |
| SP-TO/MHCF(MC) | Two-Wire Optic Sensor, flanged holder, 2 1/8" Medium Cap | 7" (175mm) | 09407L1 |
| | | 12" (300mm) | 09412L1 |
| | | 15" (375mm) | 09415L1 |
| SD-5CE | 5-Element Electronic Dummy | | 08542 |

Employed on tank trucks with less than 6 compartments (8 in Canada) when not using IntelliCheck® series monitors.

REPLACEMENT PARTS

| Model | Description | Shaft Length | Part Number |
|-------------|---|--------------|-------------|
| SP-TO | Two-Wire Optic Sensor, (without holder) | 7" (175mm) | 09409L1 |
| | | 12" (300mm) | 09414L1 |
| | | 15" (375mm) | 09417L1 |
| SP-MHC(MC) | 2" NPT Threaded Holder Only | | 09065 |
| SP-MHCF(MC) | Flanged Holder Only | | 08265 |

Copyright © 2023 Scully Signal Company. Dynacheck, Dynamic Self-Checking, Dynamic Self-Testing, Faylsafe, IntelliCheck, Intellitrol are registered trademarks of Scully Signal Company. All Rights Reserved. Specifications are subject to change without notice.

Viton® is a registered trademark of DuPont. Pyrex® is a registered trademark of Corning.

02-4
June 2023



Scully Signal Company
800 272 8559
sales@scully.com
Wilmington, MA, USA

Scully Systems Europe NV
+32 (0) 15 56 00 70
sales@scully.be
Mechelen, Belgium

Scully UK Ltd
+44 (0) 1606 553805
sales@scullyuk.com
Winsford Cheshire, UK

Scully Systems India
+91 9821799566
salesindia@scully.com
Maharashtra, India

