

## Electronic Installation for 5-Wire Sensor- Black Sheath Cable

### 5-Wire Liquid Level Sensors Wired to Intellicheck®3

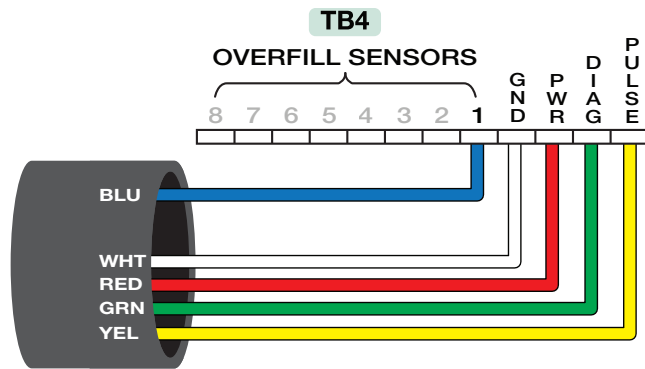

\* THE 7 CONDUCTOR BLUE SHEATH CABLE HAS A BLACK WIRE IN PLACE OF THE GREY WIRE FOR SENSOR POWER INPUT.

### 5-Wire Liquid Level Sensors Wired to Optic Socket

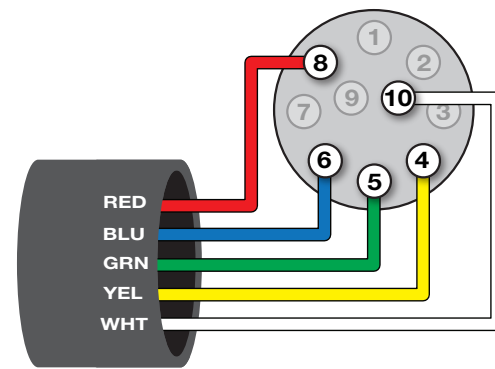

## Technical Specifications

### Operating Temp. Range:

-40°F to +140°F (-40°C to +60°C).

### Petroleum Product Range:

Gasoline blends and light fuel oils.

### Exposed Materials:

Aluminum, borosilicate (Pyrex®) glassepoxy, conductive nylon and Viton® seals.

### Level Repeatability:

±1/16" (±1 mm).

### Detection Level and Size:

The detection level is adjustable.

### Approvals:

The sensor is intrinsically safe for mounting in Class I, Division 1, Groups C & D Hazardous location in accordance with Scully Control Unit approval ratings.

The sensor is intrinsically safe for mounting in Zone 0 according to ATEX Directive 94/9/EC  
Ex ia IIB T5 Ga (-40°C ≤ Ta ≤ +60°C)

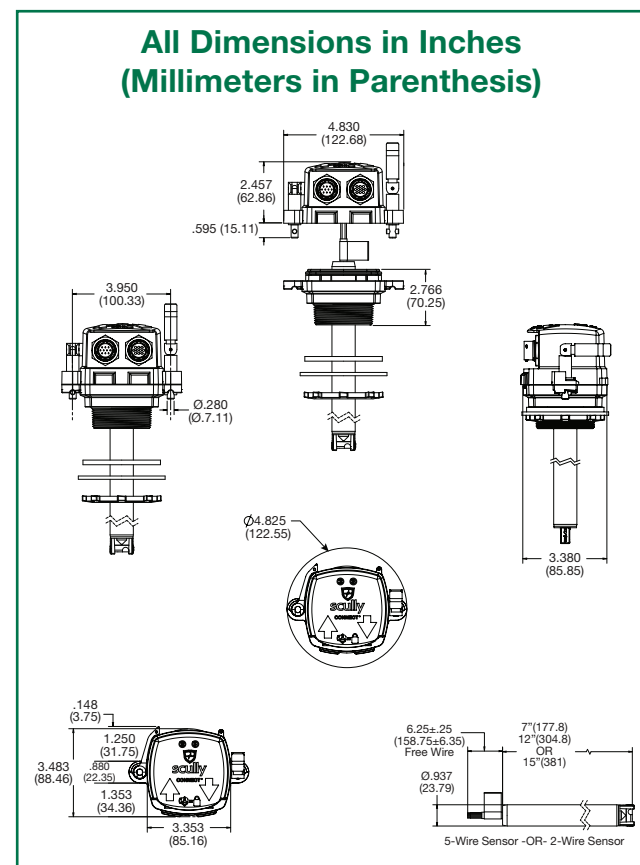

# SCULLY CONNECT™ Plus Installation Instructions

## Overfill Sensor Mechanical Installation

The sensor is designed to withstand vibrations in road transport. However, the sensor should not be subjected to any mechanical impact as it may damage the sensor. The sensor assembly should be mounted in the top of a tank trailer compartment close to the longitudinal centerline of the tank. In many cases, it is most practical and convenient to mount the sensor holder in the manlid assembly of the compartment. Many manlid manufacturer's provide a threaded or through-hole opening for an overfill prevention sensor in the manlid assembly. In choosing a mounting location other than in the manlid assembly, consider locating the holder in an area where the sensor can be conveniently reached from the access opening in the manlid assembly. This will greatly simplify installing the sensor and any future maintenance to the sensor.

## Installation Options

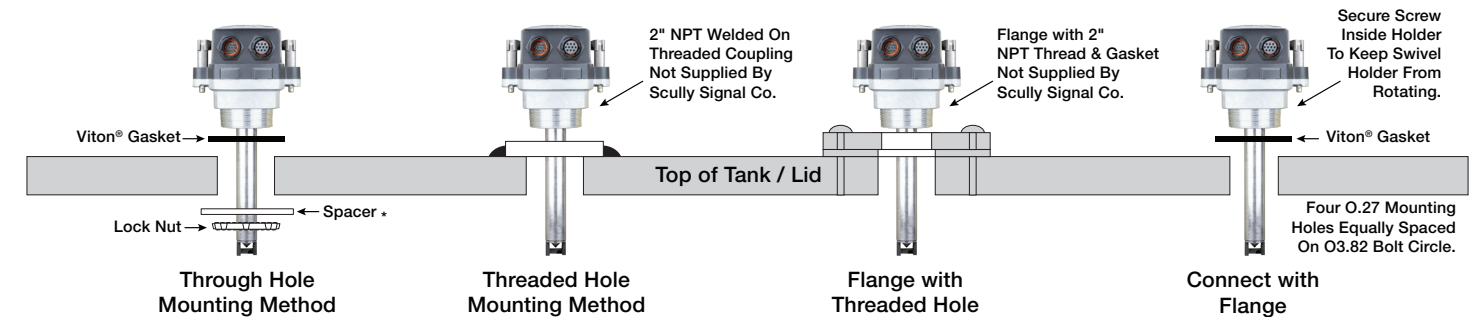

\* USE ONLY IF MOUNTING PLATE THICKNESS IS 3/16" (4.8mm) OR LESS. DISCARD IF NOT USED.

## Opening and Adjusting Sensor

### Option 1: No Space Limitation

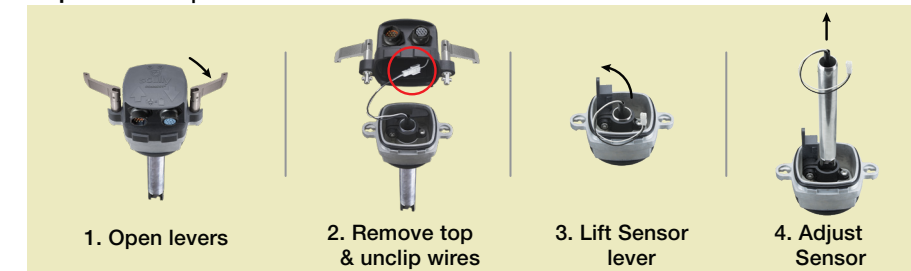

### Option 2: In Tight Spaces

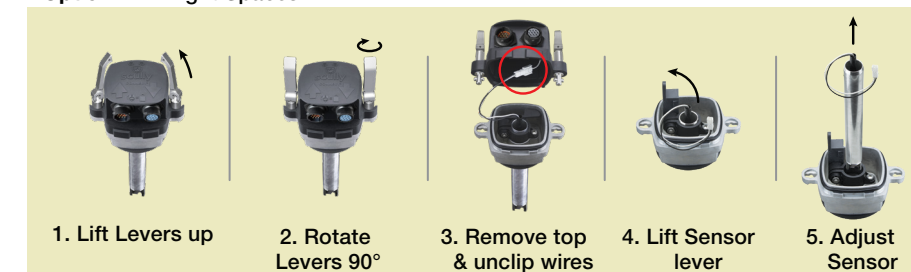

## Connecting



\* CAP MUST BE SEATED FULLY ON TO BASE BEFORE CLOSING LEVERS. EXCESSIVE FORCE ON LEVERS MAY CAUSE DAMAGE.

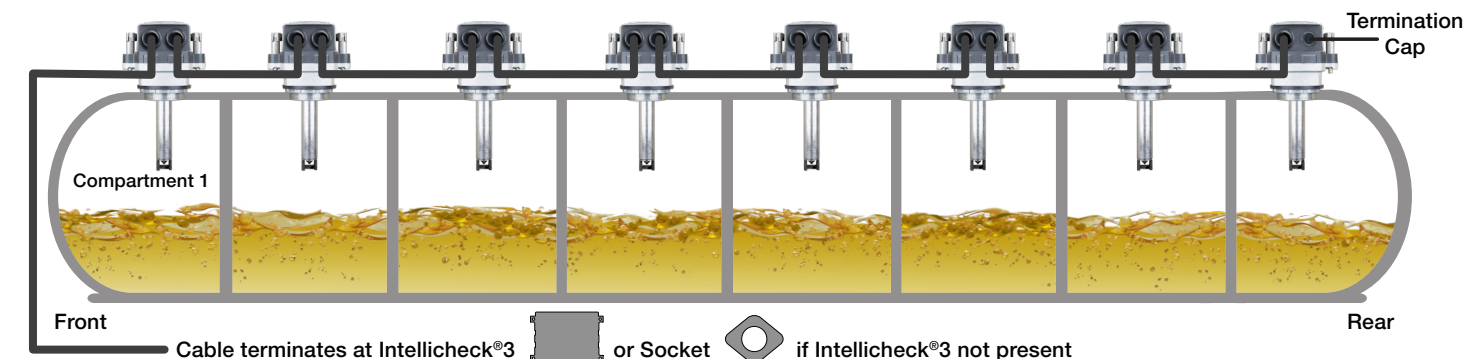

\* CAP CONNECTIONS FACING CURBSIDE ENABLES EASY CABLE ROUTING.



For more information and 24 hour technical assistance, call Scully Signal Company at 800-272-8559 or email sales@scully.com

Copyright ©2023 Scully Signal Company. Scully Connect, Dynacheck, Dynamic Self-Checking, Dynamic Self-Testing, Faysafe, Intellicheck3, are registered trademarks of Scully Signal Company. All Rights Reserved. Specifications are subject to change without notice.

603000016 Rev B  
June 2023

Patent Pending

## Electronic Installation for 2-Wire Sensor- Black Sheath Cable

### 2-Wire Liquid Level Sensors wired to Intellicheck®3 Overfill Sensor inputs (TB4)

1. Compartment counting starts from the front of the truck. Compartment 1 is always the **BROWN** wire.
2. Connect compartment 1 sensor **BROWN** wire to TB4 terminal 1.
3. Connect additional compartment sensors (2 – 8) to TB4 terminals 2 – 8.
4. Connect only wires for active compartments. **DO NOT** connect wires from non-existent compartments.
5. Connect **WHITE** ground wire to TB4 GND terminal.
6. All 2-Wire sensors should be wet-tested after electrical installation is completed to confirm functionality.  
Refer to proof test as detailed in Scully ST-15 safety manual pn 61626.

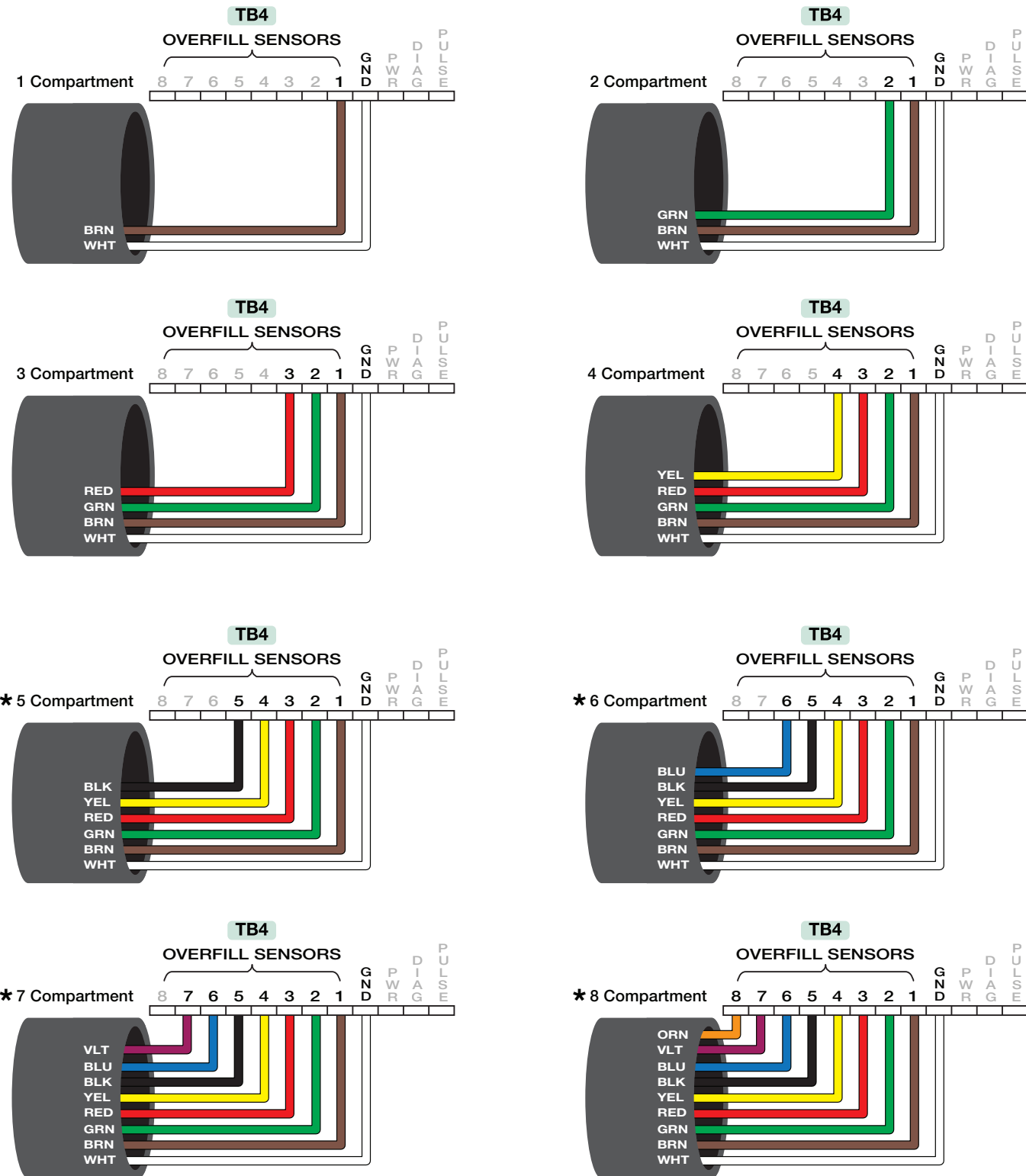

\* FOR 7 CONDUCTOR CABLES, THE BLACK WIRE IS REPLACED BY ORANGE (COMPARTMENT 5).  
\* THE 9 CONDUCTOR CABLE SUPPORTS UP TO 8 2-WIRE COMPARTMENTS, AS THE 7 CONDUCTOR CABLE SUPPORTS UP TO 6 2-WIRE COMPARTMENTS.

### 2-Wire Liquid Level Sensors Wired to Thermistor Socket

1. Compartment counting starts from the front of the truck. Compartment 1 is always the **BROWN** wire
2. Connect compartment 1 sensor **BROWN** wire to truck socket pin 3
3. Connect additional compartment sensors (2 – 6) to truck socket pins 4 to 8 as shown below
4. Connect only wires for active compartments to socket. **DO NOT** connect wires for non-existent compartments
5. Connect dummy wires to remaining socket pins (4-8) as shown below
6. Connect **WHITE** ground wire to socket pin 10
7. All 2-Wire sensors should be wet-tested after electrical installation is completed to confirm functionality.  
Refer to proof test as detailed in Scully ST-15 safety manual pn 61626.

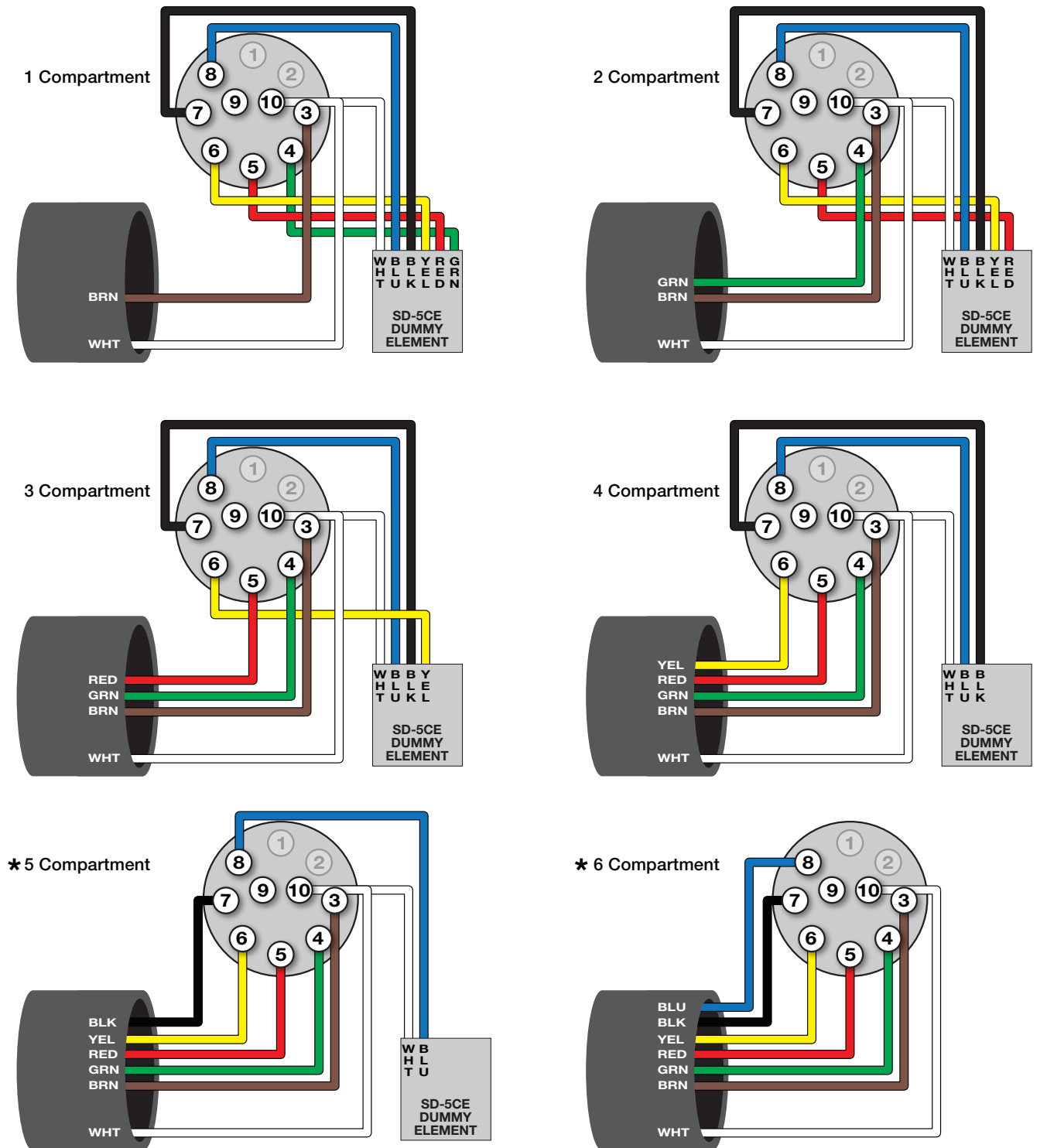

\* FOR 7 CONDUCTOR CABLES, THE BLACK WIRE IS REPLACED BY ORANGE (COMPARTMENT 5).  
\* THE 9 CONDUCTOR CABLE SUPPORTS UP TO 8 2-WIRE COMPARTMENTS, AS THE 7 CONDUCTOR CABLE SUPPORTS UP TO 6 2-WIRE COMPARTMENTS.