

Scully ST-35C

Technical Manual



*Multiple Point Overfill Prevention
Control Monitor*



ST-35C - Technical Manual

Table of Contents

General

1.1	Description	4.
1.2	Technical Specifications	6.
1.3	Accessory Equipment	7.

Installation

2.1	Mechanical Installation	8.
2.2	Electrical Installation	8.
2.3	Initial System Checkout	10.
2.4	System Operation	11.

Maintenance

3.1	Enclosure	12.
3.2	Corrosion Protection	12.
3.3	Control Module (Circuit Board)	12.
3.4	Module Replacement	12.
3.5	Indicator Lights	14.
3.6	Control (Bypass) Switch	14.
3.7	Junction Box and Plug & Cable Unit	14.
3.8	Fuses Replacement Description	14.
3.9	Troubleshooting	15.

Diagram Appendix

4.1	DWG 31412 – Outline Drawing – Control Unit Enclosure	16.
4.2	DWG 63039 – Outline Drawing – Sculcon Junction Box	17.
4.3	DWG 61441 – Wiring Diagram - Typical Loading Rack Control	18.
4.4	DWG 61442 – Mounting Diagram – Control Unit & Junction Box	19.
4.5	DWG 31306 – Internal Wiring Diagram – ST-35C-EL	20.
4.6	DWG 31307 – Internal Wiring Diagram – ST-35C-ELK	21.
4.7	DWG 61145 – Installation Wiring Diagram	22.
4.8	DWG 61406 – Installation Wiring Diagram, ST-35C/ST-47C	23.
4.9	DWG 61559 – Replacement Parts ST-35C-120 VAC	24.
4.10	DWG 61224 – Replacement Parts ST-35C-240 VAC	25.

The ST-35C Control Unit is used for overfill prevention at loading terminals. In most tank truck loading applications, volume to be loaded into each compartment is pre-set via a pre-set meter. Under normal conditions the pre-set meter shuts down the loading after the pre-set volume is loaded. The liquid does not reach the overfill sensor as it is set at a level higher than the rated capacity of each compartment. However, if the liquid level goes above the rated capacity of a compartment, Scully's ST-35C Overfill Prevention system detects this overfill condition and shuts down the loading. Thus, it acts as a secondary (emergency) shutdown system, primary shutdown control being provided by the pre-set meter.

The ST-35C Overfill prevention Control Unit interfaces with 5-wire optic sensors. It is typically used for overfill prevention on bottom loading or top loading vehicles. It can monitor multiple sensors (i.e. multi-compartment vehicles). It is mounted at the loading rack/gantry and connects to the vehicle via a Scully plug and cable assembly.

The system incorporates Scully's unique and exclusive Dynacheck® concept. To ensure that it will always detect an overfill condition, the controller uses pulsed signals which continuously check the entire system operation including the controller, wiring connections and sensors. If a sensor comes in contact with liquid, or in the unlikely event of a system fault, the pulsed signals cease, and the controller automatically signals for immediate shutdown of the loading operation.

The ST-35C uses intrinsically safe voltage and current to connect to Scully liquid level sensors and provides control for external electrical devices by opening and closing relay contacts.

Scully loading rack overfill protection monitors have been carefully engineered to provide reliable and safe performance when installed in conjunction with related Scully equipment according to the instructions in this manual. Adaptations of, and additions to this equipment such as the use of multiple cables and plugs, loading arm position indicating switches, enclosure heaters and similar peripheral devices may void warranties unless authorized in writing by Scully Signal Company. Please contact Scully prior to performing any installation or maintenance not specifically described in this manual.

1.1 Description

The ST-35C is for use with Scully 5-Wire Optic Sensors, Model SP-FU series. It can monitor up to twelve (12) of these sensors in a "series" signal path. If any one of the connected sensors senses liquid, the ST-35C will respond to this "wet" condition; output relay contact opens, and red light turns on. Although its typical application is monitoring of sensors mounted on multi-compartment vehicles, it is also used for high level detection in storage tanks (tank farms). One relay output contact is provided, which opens if any sensor detects liquid.

ST-35C is also used with vehicles equipped with Scully's IntelliCheck® series or ONBOARD Overfill Prevention Monitors. It interfaces with 5-wire optic socket on these vehicles. The ST-35C Control Unit has an explosion proof enclosure for mounting in locations that are classified as hazardous.

Multiple Point Overfill Prevention Control Monitor

General

1.1.1 Model Designations

The ST-35C Controller is available in 120VAC or 240VAC models, with or without control (bypass) switch.

Model suffix (E) = Explosion-proof Enclosure, (L) = Indicator Lights, (K) = Key Lockable Bypass Switch.

Model	Description
ST-35C-120 EL	Multiple-Point Controller in Explosion-proof Enclosure with Indicator Lights, 120VAC
ST-35C-120 ELK	Multiple-Point Controller in Explosion-proof Enclosure with Indicator Lights and Key-lockable Bypass Switch, 120VAC
ST-35C-240 EL	Multiple-Point Controller in Explosion-proof Enclosure with Indicator Lights, 240VAC
ST-35C-240 ELK	Multiple-Point Controller in Explosion-proof Enclosure with Indicator Lights and Key-lockable Bypass Switch, 240VAC

1.1.2 Explosion Proof Enclosure

Suffix “E” in the model number indicates controller is in an explosion-proof enclosure suitable for hazardous areas. Conduit holes are provided in the enclosure for electrical access. **The installer must install Exd cable glands (or conduit and seal fittings) according to local codes.**

1.1.3 Indicator Lights

Suffix “L” in the model number indicates red and green indicator lights on the controller enclosure. These lights indicate the following conditions:

GREEN	RED	Condition
ON	OFF	All optic sensors are dry and the circuit is functioning properly. Controller output is in permissive state i.e. permit to load.
OFF	ON	One or more sensors are wet or faulty or no connection to sensors, or the circuit is malfunctioning. Controller output is in non-permissive state i.e. no permit to load.
OFF	OFF	No power to the unit or Bypass Control Switch is in OFF or BYPASS position.

1.1.4 Bypass Control Switch

Adding the suffix “K” to the model number adds a lockable three-position control switch to the enclosure.

- In the ‘OFF’ position, there is no power to the unit.
- In the ‘NORMAL’ position, the unit will operate normally, with “dry” sensors causing the output relay to become energized (i.e. closed output contact).
- In the “BYPASS” position, power to the unit is switched “OFF” and the normally open relay contacts are bypassed to permit emergency operation of the equipment, without overfill protection.

For normal operation, this switch should always be set in the NORMAL position. The switch is enclosed in lockable box to allow locking with a user provided padlock.



CAUTION: When in ‘BYPASS’ mode the controller and sensors are DISABLED and the system does not provide overfill protection.

ST-35C - Technical Manual

General

1.1.5 Indicator Light on Control Module

An internal red LED light is provided on the control module for convenience in checking the output status when the cover is open. The light is ON when power is applied and dry and functional sensors are connected to the unit. Thus, the internal light is ON when external green light is ON.

1.2 Technical Specifications

Temperature Range	-20°C to +60°C
Power Requirements	120VAC Models: 100 – 130 VAC, 50/60 Hz, 20VA Max.* 240VAC Models: 200 – 250 VAC, 50/60 Hz, 20VA Max.* *20VA does not include circuits controlled by the output relay contact
Sensors:	Up to 12 of Scully's 5-wire optic sensors, Model SP-FU series.
Output Relay:	One normally open volt-free contact rated 250VAC, 5A resistive max. The output contact closes when all sensors are dry and functional.
Response Time:	0.5 second maximum
Indicator Lights:	Output status indicator lights: Red: Non-permissive Green: Permissive
Output Control Fuse:	Internal 5 Ampere
Connections:	Provided by internal terminal strips.
Enclosure:	Explosion-proof, weatherproof IP65.
Dimensions:	See Appendix 4.1 for outline drawing.
Weight:	12.7 Kg (28 Lbs.)
Approvals:	Baseefa02ATEX0047 Ex db [iaGa] mb IIB T5 Gb Ta=-40°C to +60°C or Ex db mb [ia Ga] IIB T6 Gb  The enclosure contains associated electrical apparatus to Baseefa02ATEX0148U [Ex ia] IIB (Tamb-40°C to +70°C) Gb

Degree of protection of enclosure IP65. The rating of the enclosure is negated if the holes in the enclosure are unplugged/unscrewed or any holes are drilled into the enclosure.

The ST-35C control unit has been designed to be impact-resistant. Do not subject to excessive mechanical or thermal stresses. Do not allow the unit to come in contact with aggressive substances that may degrade the integrity of the enclosure.

The ST-35C may only be repaired by replacing the internal control module. The internal control module is non-repairable.

Do not open when an explosive gas atmosphere is present.

General

1.3 Accessory Equipment

In addition to the control unit, a plug and cable assembly is needed to provide the inter-connection from the ST-35C Control Unit to the vehicle. Plug and cable assemblies are available with various plugs conforming to industry standard configurations and with coiled or straight cables in various lengths.

Scully highly recommends the use of our Sculcon® Junction Box with Plug and Cable assembly. Use of Sculcon junction box simplifies system installation and provides for easy service of the plug and cable assembly for maintenance. Wiring the plug and cable assembly directly into the bottom of the ST-35C enclosure is not recommended and will result in greatly increased maintenance time and difficulty when the plug and cable assembly requires maintenance.

1.3.1 Sculcon Junction Box with Plug and Cable Assembly

One of the following models is needed to make connection to a vehicle. The selection is based on the style of socket used on the vehicles. “W” style plugs connect to “W” style sockets (i.e. with 3 J-slots). “B” style plugs connect to “B” style sockets (i.e. 4 J-slots).

Model	Description
SC-6W	Sculcon Junction Box with 6W Blue Poly Plug & Cable. The 6W style plug has 3- bayonet pins (for attachment to truck socket) and 6 contact pins. The SC-6W is available with either a 9 meter (30 feet) Coiled Cable or 6 meter (20 feet) Straight Cable configuration. This plug style is the standard in countries/regions that employ 3 J-slot sockets on vehicles with 5-wire optic sensors
SC-6OB	Sculcon Junction Box with 6OB Blue Poly Plug & Cable. The 6OB style plug has 4- bayonet pins (for attachment to truck socket) and 6 contact pins. The SC-6OB is available with either a 9 meter (30 feet) Coiled Cable or 6 meter (20 feet) Straight Cable configuration. This plug style is used in countries/regions that employ 4 J-slot sockets on vehicles with 5-wire optic sensors.

Consult factory for additional models.

The ST-35C control system is typically installed in areas that are classified as hazardous locations due to nature of the products being loaded. Installation of the control unit and accessories must therefore be done by qualified personnel in accordance with all national and local regulations (codes) governing the installation of electrical equipment in hazardous locations.

It is essential that the ST-35C control unit and accessories be installed and used in accordance with the detailed specifications and instructions in this manual. **Installations that violate national and local regulations (codes) for installation of electrical equipment in hazardous locations and/or details in this manual may lead to unsafe operation.**

Intrinsically safe wiring to/from TB2 at the bottom of the control module must enter/exit the bottom opening in the control unit enclosure labeled “Intrinsically Safe Entry”. Intrinsically safe wiring must be kept physically separated from any other wiring.

2.1 Mechanical Installation

When choosing a location on the loading rack for the control unit, the lights on the front of the control unit should be readily visible and within easy reach of the user. The control unit should be mounted vertically, in a location where the cover can open for servicing. (See Diagram 61442 in Appendix 4 for installation.)

Refer to the Outline Drawing 31412 in Appendix 4.1 for physical dimensions, location of the mounting bolts, electrical cable/conduit entry locations and enclosure earth bonding stud. The enclosure earth-bonding stud is provided for proper electrical bonding (earthing) of the enclosure to earth (ground). **Use only the three conduit entry holes provided for wiring. The top two holes are for power and control wiring. The bottom hole is for intrinsically safe sensor wiring only. Do not drill any additional conduit holes in the enclosure; doing so violates the enclosure’s hazardous location approval and voids the warranty.**

To avoid future maintenance issues regarding water infiltration into the enclosure via the electrical cable entries, we strongly recommend the following precautions:

1. Minimize long vertical cable (or conduit) runs into the top of the enclosure as long vertical runs promote water channeling to the cable gland.
2. The cable glands at the top of the enclosure should be very carefully installed, taking extra precaution to make certain that the installation is proper and sealed (as required by code).
3. **Must seal all enclosure cable gland entries to maintain IP65 rating and protect against water infiltration. Install a fiber washer between the cable gland and the enclosure.**

2.2 Electrical Installation

Refer to the Installation Wiring Diagrams in Appendix 4.

All cable entry fittings, junction boxes, connections, wiring, etc. are to be provided by the installer. Explosion-proof cable glands must be employed for cable entry. If conduits are used for cable entry, seal fittings must be installed in each conduit (See Wiring Diagram 61145).

Multiple Point Overfill Prevention Control Monitor

Installation

There are three holes in the enclosure for cable entry. Two holes in the top of the enclosure are for mains power and control output wiring. One hole in the bottom of the enclosure, labeled “Intrinsically Safe Entry” is for connection to sensors, via a Scully Sculcon Junction Box and Plug & Cable.

WARNING: *The electrical cable entry in the bottom of the enclosure marked “INTRINSICALLY SAFE ENTRY” must only be used for wiring to the sensors (via plug and cable assembly). To maintain intrinsic safety, this cable entry must not be used for any other wiring. DO NOT ROUTE MAINS POWER THROUGH THIS HOLE.*

2.2.1 Power Connections

Route the mains power wires through the top left-hand entry hole in the top of enclosure. Connect mains power wires to appropriate terminals on terminal block (strip) on the metal bracket in the enclosure. The Power terminals are marked E, N, & L, also shown in wiring diagram.

NOTE: *The ST-35C Control Module is protected by a fuse (F1) in the enclosure located next to the terminal strip on metal bracket. See replacement part in appendix 4.9 or 4.10.*

2.2.2 Enclosure Earth (Ground) Connection

Connect a wire (1.5mm² or 16 AWG minimum) from the enclosure-bonding stud to earthed metallic structure of the gantry (rack).

2.2.3 Control Output (Controlled Circuit) Connections

Route the control output wiring through the top right hand entry hole in the enclosure and connect to output contact terminals, indicated on the terminal strip on metal bracket. The output control contact is open when no connection from the controller is made to a vehicle (idle state). The output control contact closes when all of the optic sensors connected to the control unit are dry and functional (or when optional bypass switch is in the “Bypass” position).

The contact opens if a sensor gets wet (i.e. detects liquid). The contact also opens in case of a fault in any sensor, wiring to the sensors or a fault within the control units’ circuitry.

NOTE: *An internal fuse (F2) protects the output relay contact, located on metal bracket. See replacement part in appendix 4.9 or 4.10.*

The output contact is rated 250VAC, 5A resistive maximum. It is used to close a valve or pump directly or by wiring it in series with other control contacts, such as a preset meter’s control contacts. (See diagram 61441, Typical Loading Rack Control in Appendix 4) In addition it may also be connected to an input of a terminal automation system (TAS) to provide status of the controller’s output to TAS.



Caution: *A valve or pump should be directly controlled by ST-35C’s relay output contact. It should not go via the logic circuits of a TAS, as that can introduce unsafe failure modes into this emergency shutdown system. TAS may also control a valve or pump based on other conditions.*

2.2.4 Intrinsically Safe Connections to Sculcon Plug & Cable Unit

Signals from ST-35C to Sculcon Plug & Cable Unit are intrinsically safe. The intrinsically safe connections must only be made via the entry hole in the bottom of the enclosure. The connections are made to the terminal strip TB2 at the bottom end of the printed circuit board module. The wires must be 1.0mm² (18AWG) minimum conductor size. Connect 4 wires to Sculcon as shown in the wiring diagram 61145 (see Appendix 4). Use wire colors as indicated (red, black, yellow and orange). If other than suggested color codes are used, this information should be so noted in the back of this manual for future reference and troubleshooting. All wiring installation should be in accordance with local wiring codes.

2.3 Initial System Checkout

2.3.1 Test Equipment

Scully suggests the use of our Universal Loading Rack Tester Model ST-2-DSWJ for individual compartment checks, cable continuity or float detection. The tester will expedite the initial system check out of the ST-35C. While not required, the tester provides all of the proper overfill prevention system signals to verify the new installation without the need to secure an actual vehicle for testing.

2.3.2 Operational Testing

Apply power to the ST-35C control unit.

The red light should be ON, provided Bypass Control Switch is in NORMAL position.

Check status of lights with Bypass Control Switch in the following positions:

OFF: Both lights should be OFF

NORMAL: Red light should be ON

BYPASS: Both lights should be OFF

Set Bypass Switch to NORMAL position, the normal operation setting. The Bypass Switch should be kept under a lock (user provided) so that its' setting cannot be tampered with, without proper authorization.

Connect Sculcon plug to socket on the tester. Follow instructions provided with the tester. As the tester simulates a vehicle equipped with 5-wire sensors, the ST-35C output will go permissive immediately with green light ON and red light OFF.

Follow instructions provided with the tester to test both permissive and non-permissive states of the ST-35C controller.

Multiple Point Overfill Prevention Control Monitor

Installation

2.4 System Operation

Connect the Sculcon plug to socket on the vehicle to be loaded. If all sensors are dry, the ST-35C controller will go PERMISSIVE immediately (i.e. green light ON). The output relay contact closes enabling the loading to begin. If there is a fault in the sensor, wiring interconnections or the controller circuitry the controller output will stay NON-PERMISSIVE (does not allow loading to begin). If a fault develops during loading or liquid level reaches the sensor, the controller will switch to NON-PERMISSIVE (i.e. red light ON and output relay contact opens).

Disconnect Sculcon plug from the socket after the loading is complete. Hang the plug on the hook provided on the Sculcon junction box (or in Scully Plug Storage Hanger socket).



CAUTION: BEFORE PERFORMING ANY MAINTENANCE ON THE CONTROL UNIT, DISCONNECT POWER TO THE ST-35C AND WAIT UNTIL THE AREA IS KNOWN TO BE CLEAR OF ANY EXPLOSIVE GAS, BEFORE OPENING. ALWAYS REPLACE ALL BOLTS WHEN REINSTALLING THE COVER.

3.1 Enclosure

Considering the location where the control unit will be typically mounted, it is advisable to inspect the enclosure routinely for deterioration due to environmental corrosion. The control unit should be opened once per year for internal inspection and replacement of the corrosion (inhibitor) capsule. Cover screws used must be minimum grade A2-70 stainless steel.

3.2 Corrosion Protection

The control unit is shipped from the factory with a corrosion inhibitor capsule adhered to the inside of the cover. The corrosion capsule is designed to condition the atmosphere within the enclosure to resist corrosion. It is intended to last approximately 1 year in normal use. As previously mentioned, the control unit should be opened once per year for internal inspection. At this time the corrosion capsule should be replaced (see Replacement Parts Sheet in Appendix Section 4.9 or 4.10).

It is also recommended to replace the cover O-ring at the same time.

3.3 Control Module (Circuit Board)

The ST-35C control unit's internal circuitry does not require any routine periodic maintenance.

The control circuitry may be repaired only by replacing the internal control module with an equivalent module. The internal module is non-repairable.



DO NOT ATTEMPT TO SERVICE OR ADJUST THE ST-35C MODULE. ATTEMPTING TO SERVICE THE MODULE WILL NEGATE WARRANTIES, CERTIFICATION AND JEOPARDIZE INTRINSIC SAFETY ASPECTS OF THE DEVICE.

If it is determined (after troubleshooting, see Section 3.8) that control module needs to be replaced, remove the faulty control module and install the replacement control module per the following steps: (See Figure 1 ST-35C Control Module Illustration on following page)

3.4 Module Replacement

REMOVING THE MODULE

1. Make sure the work area is not hazardous, by ensuring there is no hazardous gas or materials.
2. Remove (disconnect) power from the ST-35C Control Unit.
3. To open the ST-35C Control Unit cover, remove the (16) hex socket head bolts by using a 6mm hex wrench.
4. Mark/label wires connected to TB1 on printed circuit board (to be able to reconnect to the same terminal numbers on the replacement module).
5. Disconnect all wires connected to TB1.
6. Mark/label wires connected to TB2.
7. Disconnect all wires connected to TB2.
8. Remove the Control Module assembly by loosening the four-(4) mounting screws located in the four corners of the Control Module assembly.

Multiple Point Overfill Prevention Control Monitor

Maintenance

INSTALLING REPLACEMENT MODULE

1. Place the new Control Module onto the mounting plate and attach the (4) mounting screws.
2. Reconnect the wires to TB2.
3. Reconnect the wires to TB1.
4. Close the cover and attach the (16) cover bolts.
5. Apply power to the Control Unit.

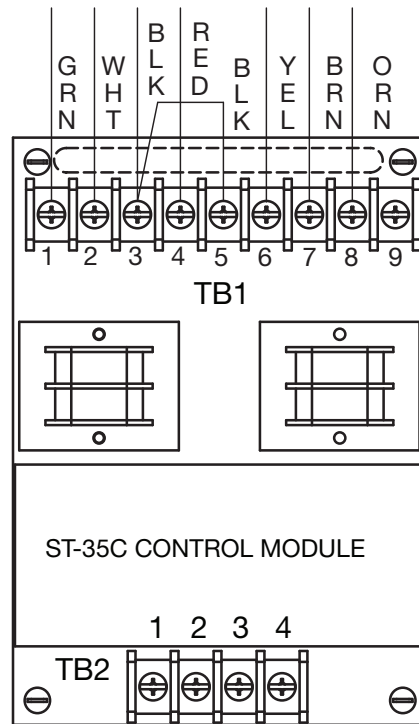

Figure 1: ST-35C Control Module Illustration



Note: The ST-35C Replacement Control Module cannot be repaired in the field. A damaged or faulty module must be replaced with an equivalent Scully ST-35C Control Module. The ST-35C Replacement Control Module must only be installed in Scully's explosion-proof enclosure. The enclosures' explosionproof and weatherproof integrity must be maintained.

The ST-35C Control Module should not be subjected to any mechanical impact. Do not allow build-up of dust on the Control Module.

Caution: Do not expose the Control Module to aggressive substances that may attack the exposed materials.

When used properly, contact with the control module will not cause physical injury or harm and does not pose non-electrical dangers. The unit does not produce excessive surface temperatures, or emit infrared or ionizing radiation.

3.5 Indicator Lights

The control unit employs explosion-proof LED style lights. These do not require any maintenance or changing of bulbs. In the event a light is faulty, it must only be replaced with parts numbers shown in Replacement parts Sheet in Appendix 4.9 or 4.10. Follow instructions provided with the replacement indicator lights (pilot lights).

Note: Older ST-35C Controllers employed incandescent style lights. These require replacement of bulb if it blows. Refer to Replacement Parts Sheet in Appendix 4.9 or 4.10.

3.6 Control (Bypass) Switch

On those models having a lockable control (Bypass) switch, the switch box may be replaced by removing two screws inside the switch box. The switch box is replaced as a unit.

A faulty switch may also be replaced if necessary, see replacement parts sheet in Appendix 4 for replacement part numbers.

3.7 Junction Box and Plug & Cable Unit

The Sculcon Junction Box and Cable unit(s) require simple routine maintenance. More attention is needed in highly corrosive environments.

Although it is not required, we recommend that the exposed electrical contact of the plug be coated with a corrosion inhibiting film routinely (once per month is suggested). Corrosion inhibiting spray, ACF-50 Corrosion Block® (manufactured by Lear Chemical Research Corporation, Mississauga ON Canada www.learchem.com). Other external metal parts of these accessories may also be treated as necessary to prevent atmospheric corrosion problems.

The exterior surface of the plug should be kept clean using a mild detergent based cleaning solution and water. The cabling should be routinely wiped of foreign material and cleaned to preserve the outer jacket. To protect it from loading arm damage etc., it is important to store the plug and cable out of harms way when it is not in use. A hook is provided on Sculcon Junction Box or a Scully Storage Socket may be used.

3.8 Fuses Replacement Description

(Also see replacement Parts Sheet in Appendix 4.9 or 4.10.)

Fuse	Description	Part Number
F1	1A, 250V, 1" X 1/4", 6000A Breaking Capacity	26343
F2	5A, 250V, 1" X 1/4", 6000A Breaking Capacity	26350

Multiple Point Overfill Prevention Control Monitor

Maintenance

3.9 Troubleshooting

The following troubleshooting guide should aid in an initial diagnosis of most problems encountered with installation and operation of ST-35C.

Condition	Possible Cause
No lights ON, on front cover	<ul style="list-style-type: none">• No power to control unit• Control (Bypass) Switch in OFF position• Bulb blown (on older units with incandescent lamps)• Input power fuse (F1) is blown• Control Module is defective• Control (Bypass) Switch in BYPASS position
Green (Permissive) light ON, but control contact output does not activate valve/pump	<ul style="list-style-type: none">• Control Output fuse (F2) is blown• Wiring defect (control output contact wiring)• Control Module is defective
Red (Non-permissive) light stays ON when connected to vehicle with Scully 5-wire sensors (or Scully tester)	<ul style="list-style-type: none">• Wet or faulty sensor on vehicle• Fault in wiring to junction box and/or plug• Fault in wiring on vehicle• Bad plug to socket connection• Control Module is defective
Red LED on Control Module (circuit board) ON but Green external light OFF	<ul style="list-style-type: none">• Internal wiring fault• Control Module is defective.• Green external light defective
Red LED on Control Module (circuit board) OFF	<ul style="list-style-type: none">• No power to control unit• Control (bypass) Switch in OFF position• Input power fuse (F1) is blown• Wet or faulty sensor• Fault in wiring to sensors

Check voltage (DC) between pins 8 and 10 (ground) of the plug. It should be 8.7VDC minimum.

4.1 DWG 31412 - Outline Drawing - Control Unit Enclosure

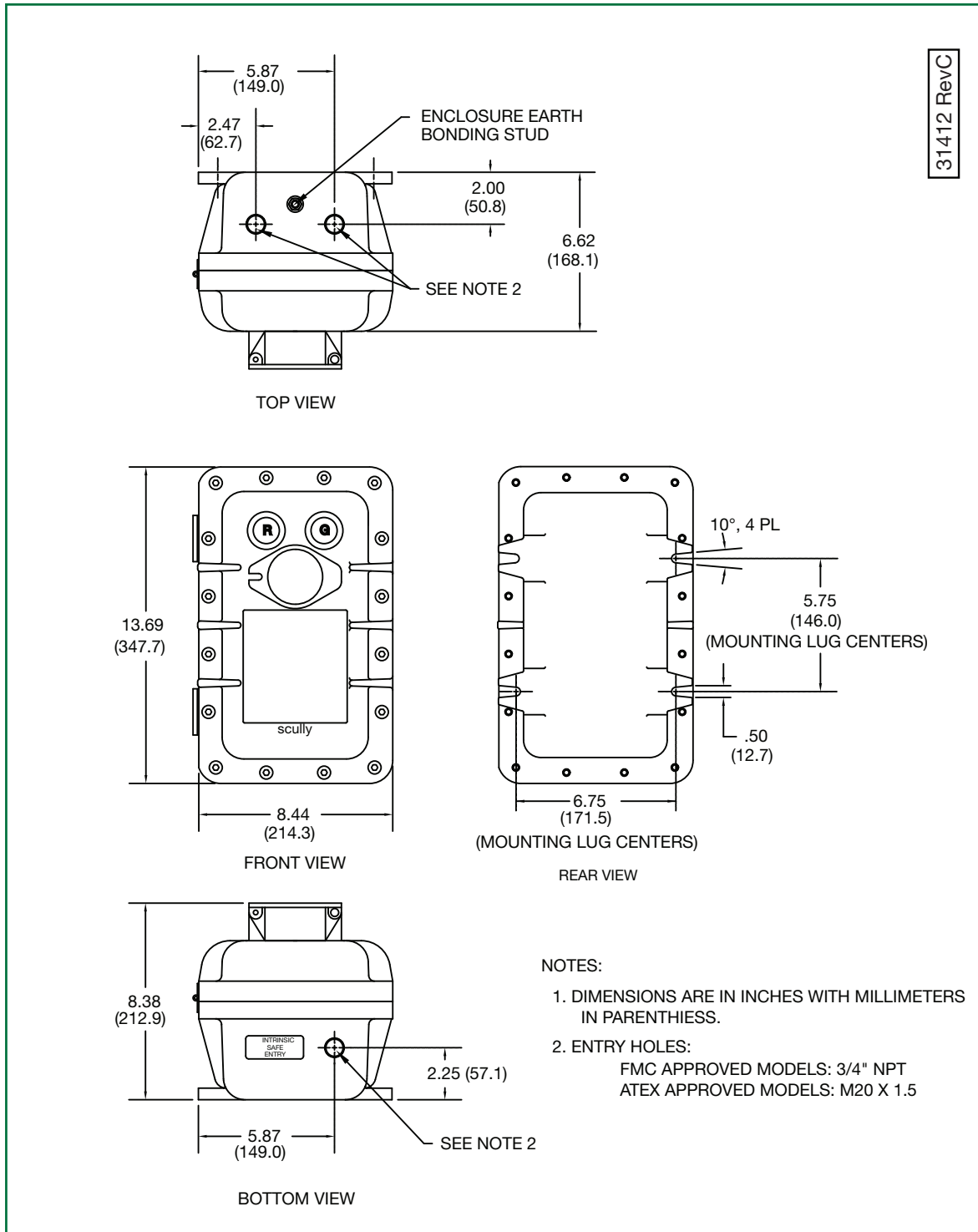

4.2 DWG 63039 - Outline Drawing - Sculcon Junction Box

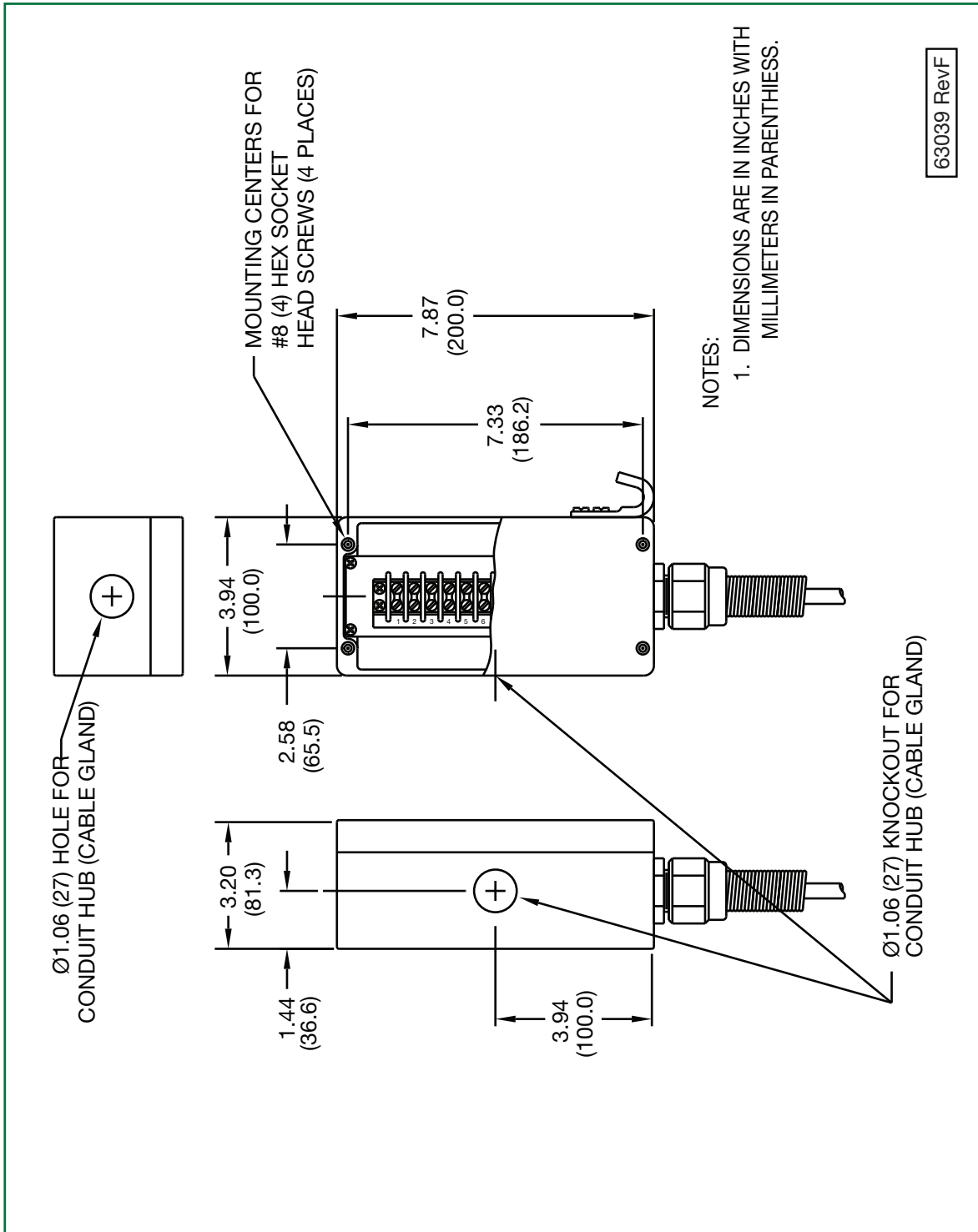

4.3 DWG 61441 – Wiring Diagram – Typical Loading Rack Control

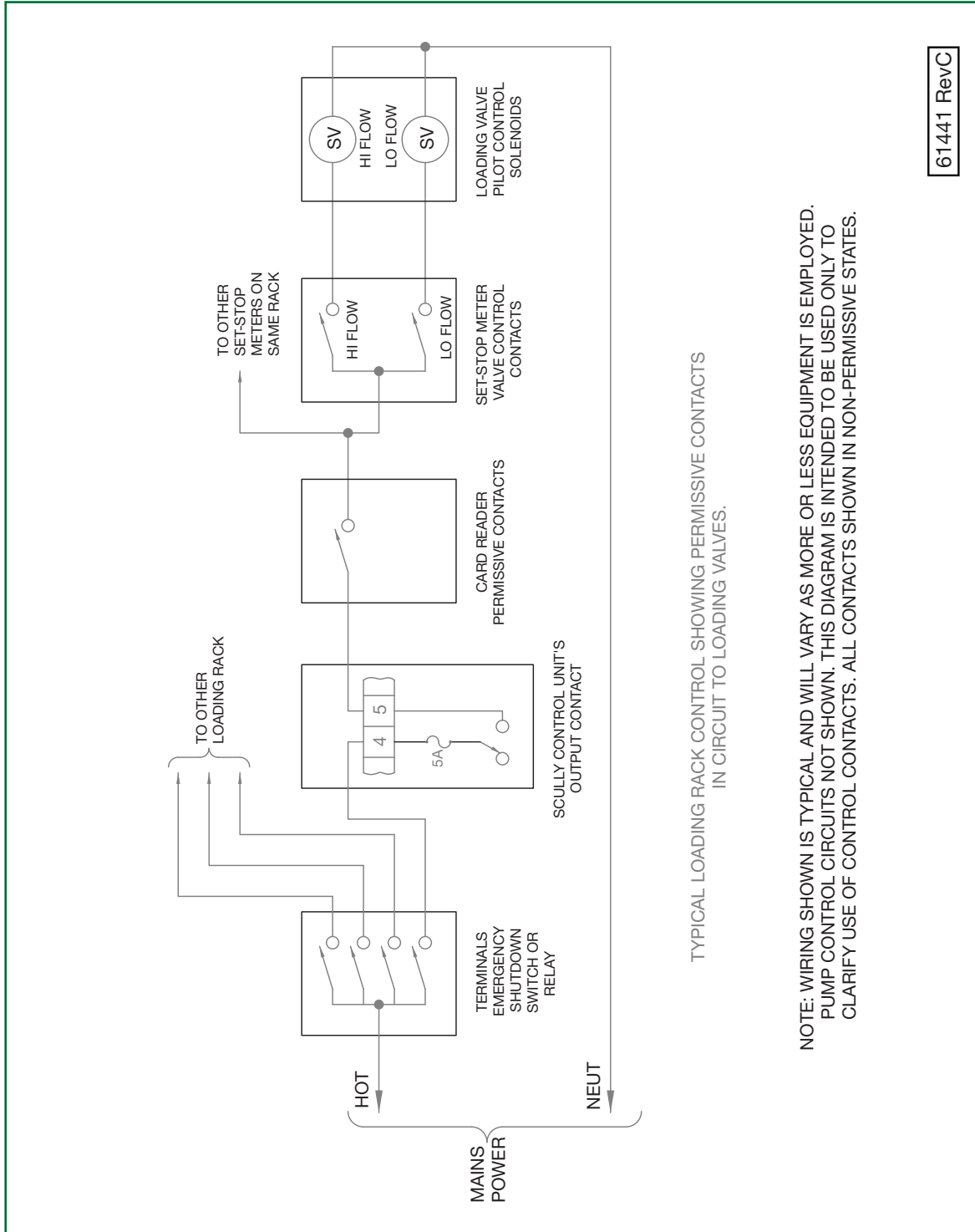

4.4 DWG 61442 - Mounting Diagram - Control Unit & Junction Box

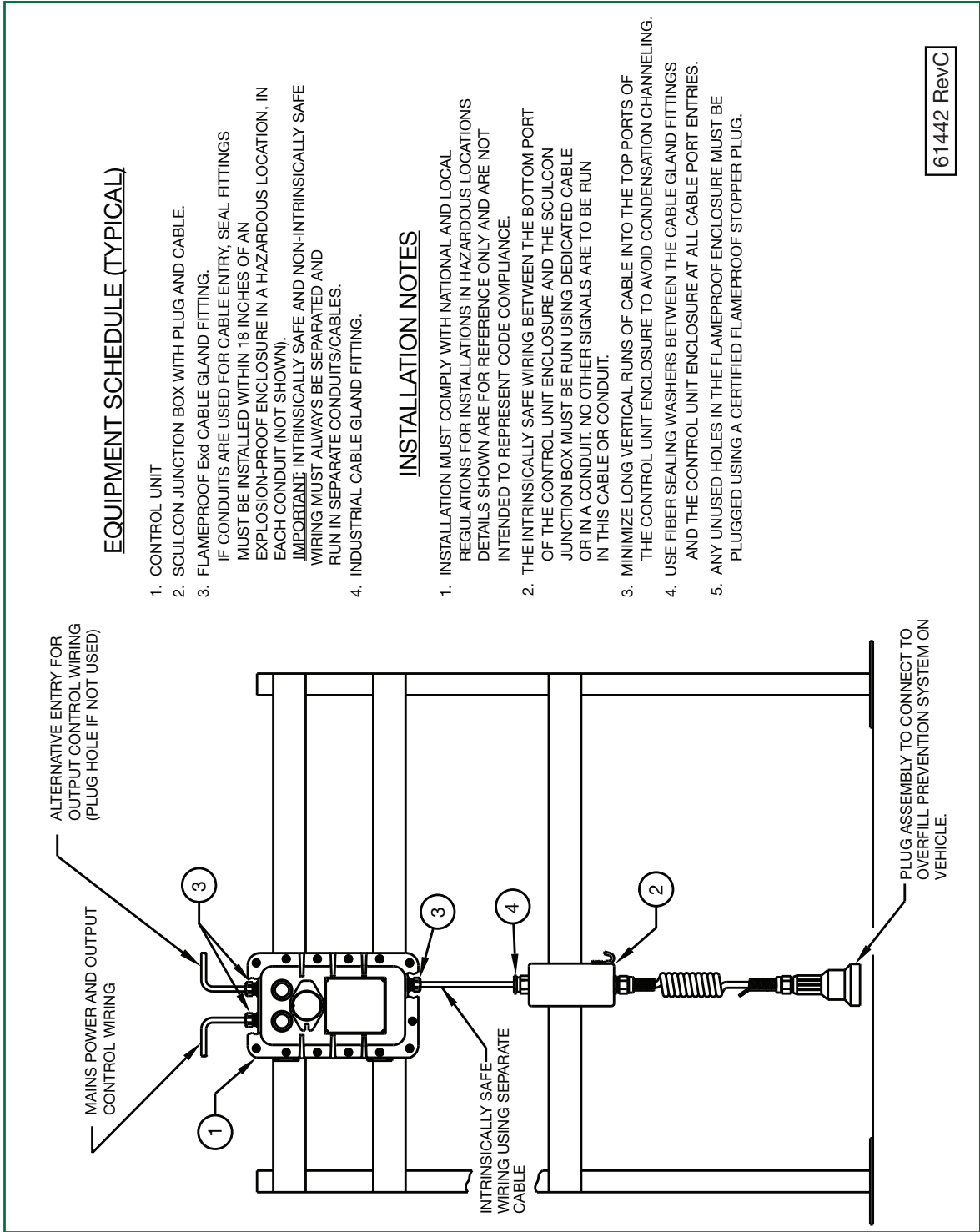

4.5 DWG 31306 – Internal Wiring Diagram – ST-35C-EL

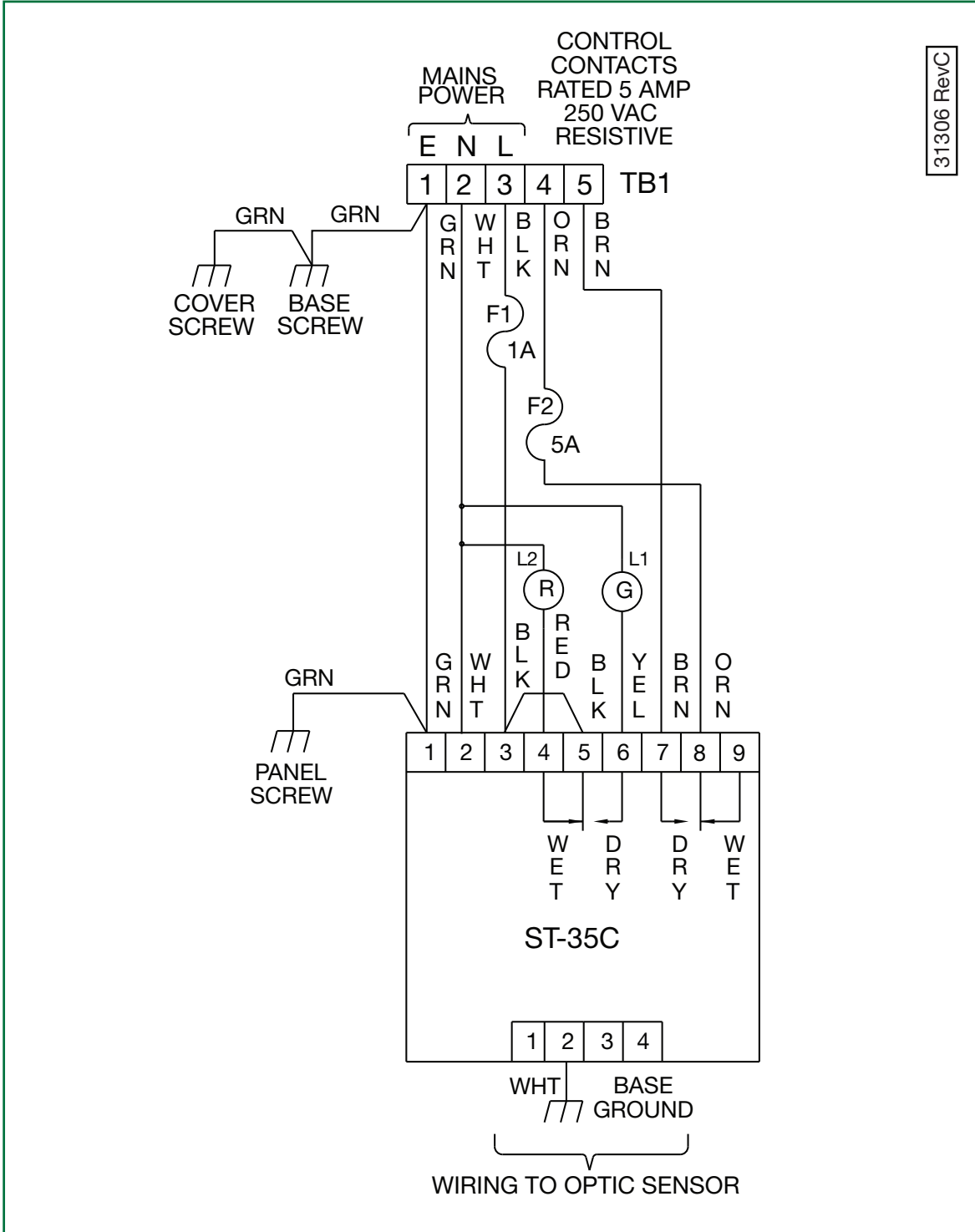

Multiple Point Overfill Prevention Control Monitor

Diagram Appendix

4.6 DWG 31307 – Internal Wiring Diagram – ST-35C-ELK

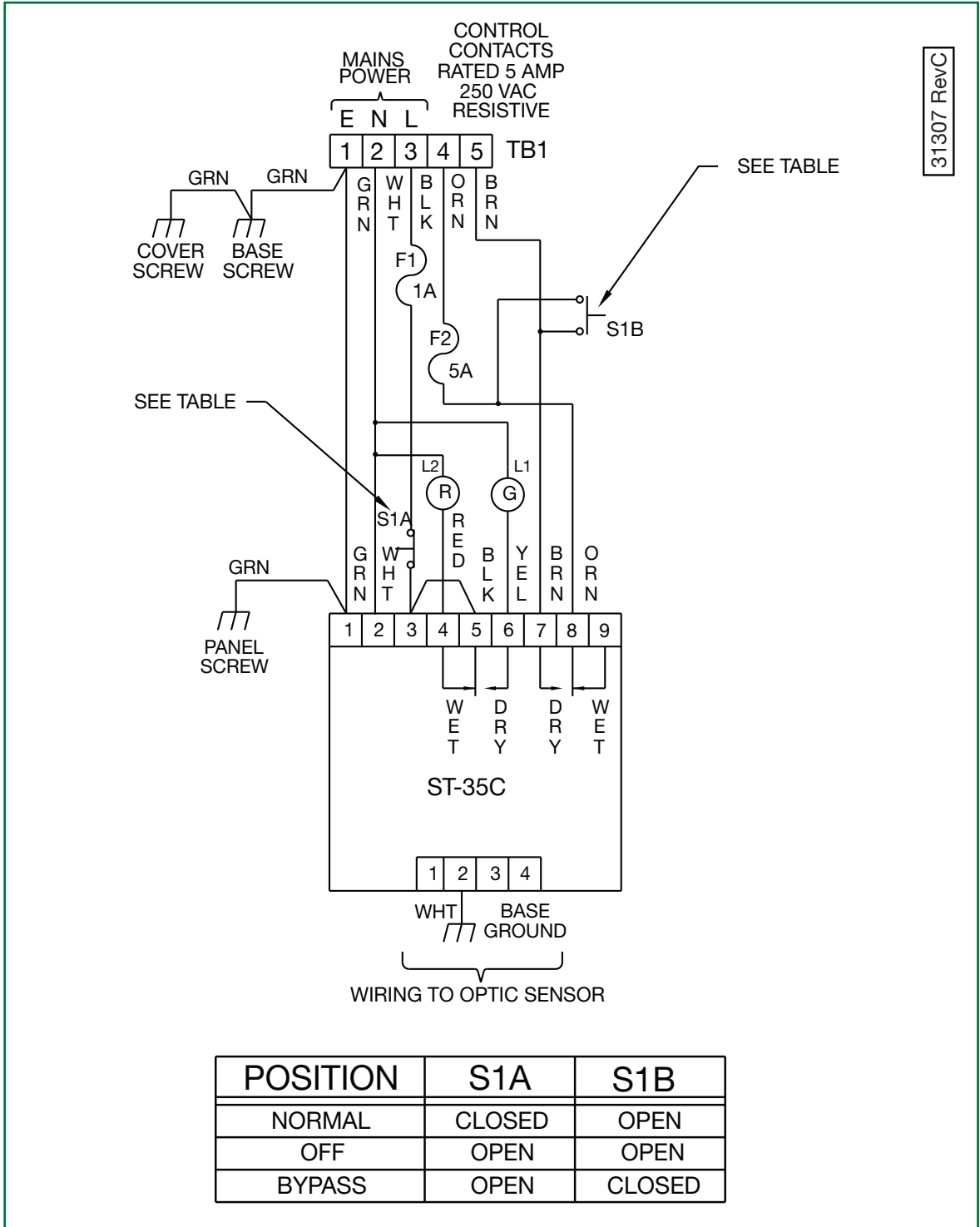

Multiple Point Overfill Prevention Control Monitor

Diagram Appendix

4.8 DWG 61406– Installation Wiring Diagram, ST-35C/ST-47C

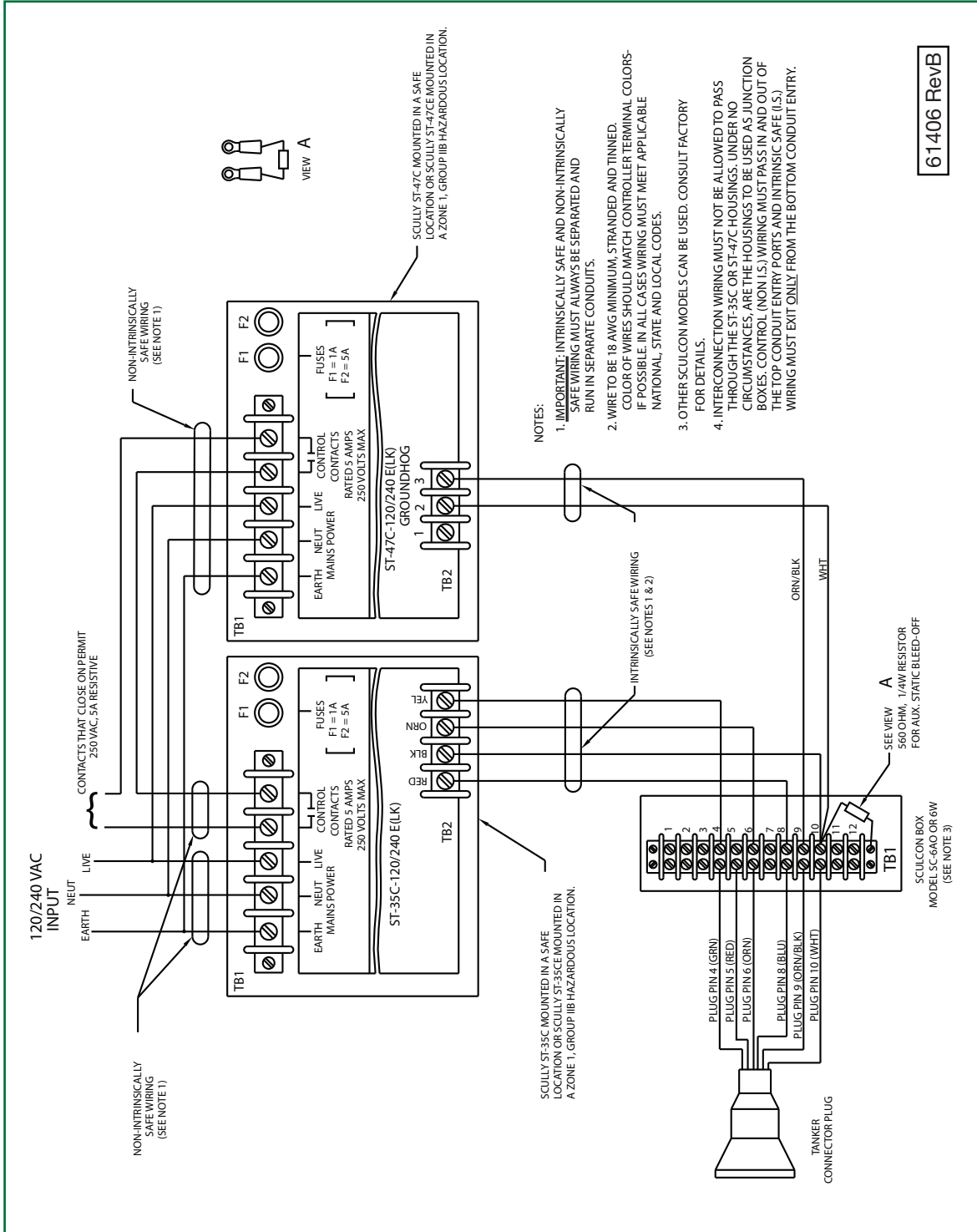

61406 RevB

4.9 DWG 61559 – Replacement Parts ST-35C-120 VAC

ST-35C 120VAC

Multi-Point Optic Controllers

CENELEC Models

Part No. Model

08811	ST-35C-120 EL
08807	ST-35C-120 ELK

Note: Controller Models Suffix:
Explosion-proof housing (E), Indicator Lights (L), Key (K) Lockable
Bypass Switch.

Replacement Parts

Item	Part No.	Description	Qty.
1	26343	Main Fuse, 1 Ampere, 1" X 1/4"	1
2	26350	Control Fuse, 5 Ampere, 1" X 1/4"	1
3	08808	ST-35C-120 Module Assembly, 120	1
4	08360	Bypass Switch Lockbox (includes 2 mounting screws)	1
5	09220	Replacement Light Explosion Proof Lamp Assembly, Green, LED Style	1
6	09221	Replacement Light Explosion Proof Lamp Assembly, Red LED Style	1
7	50005	Socket Head Cap Screw, Stainless	16
8	21733	Corrosion Capsule	1
9	31340	O-ring cover seal	1
10	26022	Bypass Switch Contact Block	1
11	26055	Bypass Switch Operator 3 Position	1
*	27085	Bulb, 120V, 6W*	

Notes:

Item 7: New socket head screw used on models built after 10/92.

Item 9: O-ring used on models built after 10/92.

Item 5, 6: LED style lamps used on models built after 2/02.

* Replacement bulb for incandescent style explosion-proof lights.
Use on models build prior to 2/02.

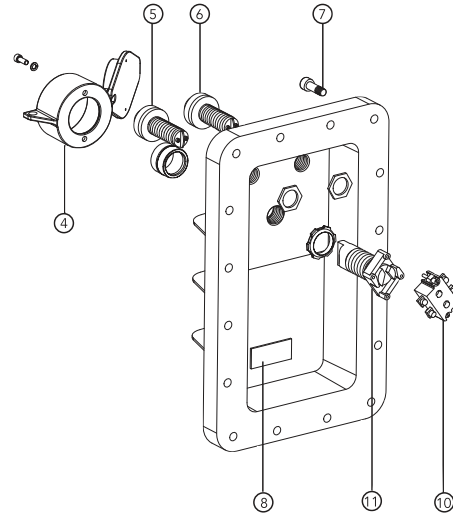
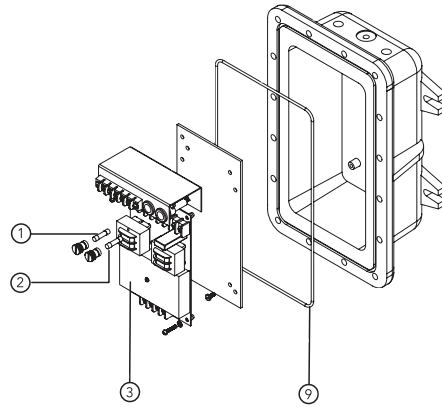

Multiple Point Overfill Prevention Control Monitor

Diagram Appendix

4.10 DWG 61224 – Replacement Parts ST-35C-240 VAC

ST-35C 240VAC

Multi-Point Optic Controllers

CENELEC Models

Part No. Model

08623	ST-35C-240 EL
08621	ST-35C-240 ELK

Note: Controller Models Suffix:
Explosion-proof housing (E), Indicator Lights (L), Key (K) Lockable
Bypass Switch.

Replacement Parts

Item	Part No.	Description	Qty.
1	26343	Mains Fuse, 1 Ampere, 1" X 1/4"	1
2	26350	Control Fuse, 5 Ampere, 1" X 1/4"	1
3	08647	ST-35C-240 Module Assembly, 240V	1
4	08360	Bypass Switch Lockbox (includes 2 mounting screws)	1
5	09420	Replacement Light Explosion Proof Lamp Assembly, Green, LED Style	1
6	09421	Replacement Light Explosion Proof Lamp Assembly, Red LED Style	1
7	50005	Socket Head Cap Screw, Stainless	16
8	21733	Corrosion Capsule	1
9	31340	O-ring cover seal	1
10	26022	Bypass Switch Contact Block	1
11	26055	Bypass Switch Operator, 3 Position	1
*	27065	Bulb, 240V, 6W*	

Note:

Item 7: New socket head screw used on models built after 10/92.

Item 9: O-ring used on models built after 10/92.

Item 5, 6: LED style lights used on models:

- a. ELK built after 8/01.
- b. EL built after 10/01.

* Replacement bulb for incandescent style explosion-proof lights only.

Use on models:

- a. ELK built prior to 8/01.
- b. EL built prior to 10/01.

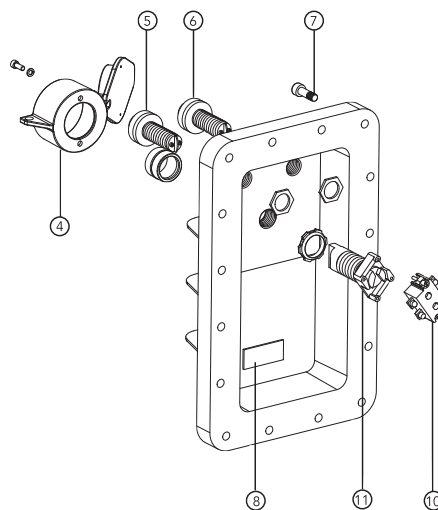
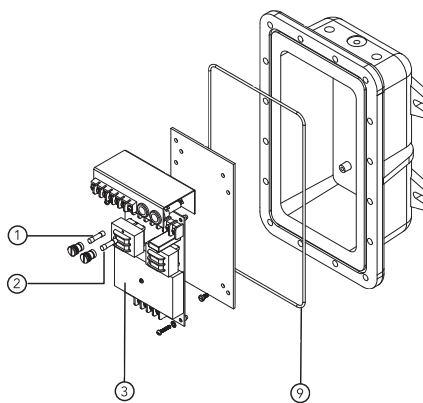

Notes:

Scully - Setting Standards in Safety and Dependability since 1936.

For over seventy-five years Scully has been engineering and building products to the highest safety and reliability standards. We design and manufacture all of our systems under one roof to ensure complete quality control over our manufacturing and testing operations. Scully is ISO certified and all of our products are 100% made in the U.S.A. In addition, we back up our products with the best service in the industry. We have direct sales and service personnel in the U.S.A., The United Kingdom, and Europe and are represented in over 50 countries.

**For more information and 24 hour technical assistance,
call Scully Signal Company at 1-800-SCULLY (1-800-272-8559).**

Scully Headquarters in Wilmington, MA U.S.A.

Copyright © 2018 Scully Signal Company. MaxSafety, Sculcon and Scully are registered trademarks of Scully Signal Company. The names and logos of other companies mentioned herein may be trademarks of their respective owners. This document is for informational purposes only. Scully makes no warranties, expressed or implied, in this document. All Rights Reserved. Specifications are subject to change without notice.

61109 Rev F
August 2019



Scully Signal Company
70 Industrial Way
Wilmington, MA 01887, USA
800 272 8559 • sales@scully.com

Scully Systems Europe NV
Maanstraat 25
2800 Mechelen, Belgium
+32 (0) 15 56 00 70 • info@scully.be

Scully UK Ltd
Meridian House, Unit 33
37 Road One Winsford Industrial Estate,
Winsford Cheshire CW7 3QG, UK
+44 (0) 1606 553805 • sales@scullyuk.com

