



Ventafil®

Portable Whistle-Stop and Fill Device for Underground Tanks

Setting Standards in Safety and Dependability since 1936.



Ventafil®

FEATURES AND BENEFITS

- Built-in anti-foam vents won't disturb sludge on the tank bottom while allowing for larger drops.
- Three-in-one unit means the driver carries only one piece.
- Fills to within 4" of the top of the tank.
- Fits 1 1/2" and 2" tank openings.
- Prevents spills and allows for product expansion.
- Available in 9", 36" or 50" lengths.

ORDERING INFORMATION

Fill Pipe Length	Inlet Connector	Model #	Part #
9"	UNIFIL	-	04828
36"	UNIFIL	VF 4814	04814
50"	UNIFIL	VF 4815	04815

Note: All Ventafil will accept 2" NPT male pipe threaded connections.

REPLACEMENT PARTS

Description	Part #
(A) UNIFIL 2" Adaptor	04332
(B) UNIFIL Cap	04316
(C) Cord & Lock Ring	04342
(D) Adaptor Gasket	11042
(E) Whistle	10308
(F) Whistle Gasket	10926
(G) Whistle Retaining Clip	10506
(H) Adjustable Plug Assembly	10925
(J) Relief Disk	10910
(K) Disk Holding Screw	50120
(L) Bearing Pad	10715
(M) Adjustable Plug Body	10949
(N) Thumb Screw	53100
(P) Stop Pad	11049
(Q) Nutplate	10909
(R) Screws w/ Locking Insert	50426

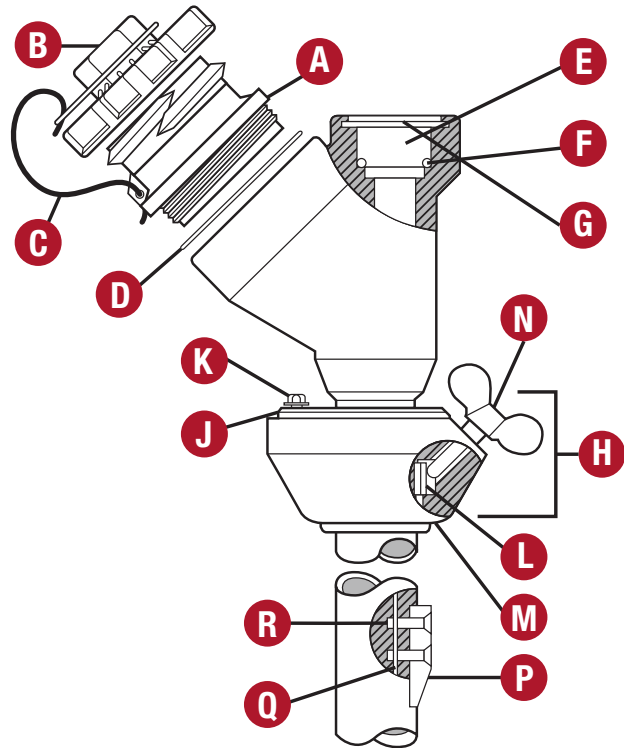

00000 Rev A
May 2015

Copyright © 2015 Scully Signal Company. Dynacheck, Dynamic Self-Checking, Dynamic Self-Testing, Faylsafe, Golden Gallon, IntelliCheck, Intellitrol, Mark IV, Sculclamp, Sculflow, Sculmatic, Twis-Lok, Unifil, Ventafil, Ventalarm, V.I.P. and Whistler are registered trademarks of Scully Signal Company. All Rights Reserved. Specifications are subject to change without notice.



Scully Signal Company
70 Industrial Way
Wilmington, MA 01887, USA
800 272 8559 • sales@scully.com

Scully Systems Europe NV
Maanstraat 25
2800 Mechelen, Belgium
+32 (0) 15 56 00 70 • info@scully.be

Scully UK Ltd
Meridian House, Unit 33
37 Road One Winsford Industrial Estate,
Winsford Cheshire CW7 3QG, UK
+44 (0) 1606 553805 • sales@scullyuk.com

