



Sculmatic® MK IV® Flow Switch Angle Check Valve

Automatic Flow Control

Setting Standards in Safety and Dependability since 1936.



MK IV

DESCRIPTION

The SCULMATIC MK V flow sensing switch activates SCULMATIC air or electric throttle actuators to increase the truck's engine from idle to full pumping speed when delivery nozzle is opened and flow begins. The SCULMATIC MK V is a discharge check valve when installed between the meter and hose reel.

FEATURES

- Pumping rate is controlled from the nozzle to permit high pumping speeds and delivery control.
- Check valve required by weights and measures.
- Flow control switch and check valve combined in one unit.
- Reduces hose pressure at idled speed and eliminates damaging surge and shock pressures.
- Available with electric or air switch.*
- Prevents hose reel movement.

* Conversion kits are complete units less the housing

Note: We recommend the use of an air filter-oiler and an air loss protection valve with any air operated Sculmatic system unless the truck's air system is already equipped with a safe, filtered and lubricated air supply.

SPECIFICATIONS

- 1/4" gauge port.
- 20 amp normally open electrical switch.
(not for gasoline use)
- Less than 7 P.S.I. pressure drop at 100 G.P.M.
- 3 P.S.I. cracking pressure at zero flow.
- Viton poppet seal.

ORDERING INFORMATION

Inlet	Outlet	Switch	Model #	Part #
2" FEMALE	2" GROOVED	ELECTRIC	SM 1000	06818
2" FEMALE	2" GROOVED	AIR	SM 1100	06817-B

Note: Scully does not currently have a Mark IV version for electronic throttles.

REPLACEMENT PARTS

Description	Model #	Part #
Air loss protection valve	SM 644	06870
Shuttle valve	SM 1053	06874
Electric conversion kit*, standard	SM 6830	06830
Air conversion kit*, standard	SM 6831	06831-B
Air switch	MK IV or MK V	11200
Poppet assembly	MK IV	36180
Viton Seal replacement kit	MK IV	11506
Air switch replacement kit	MK IV or MK V	11507
Electric switch for MK IV flowswitch	-	11508

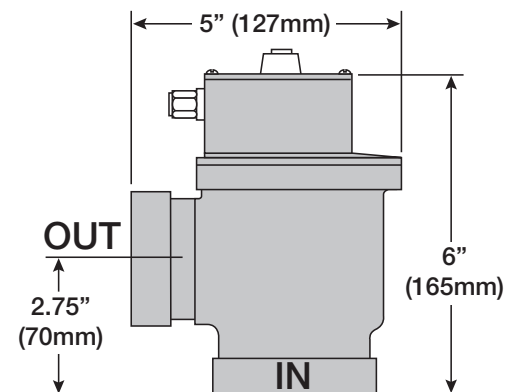

Copyright © 2017 Scully Signal Company. Dynachek, Dynamic Self-Checking, Dynamic Self-Testing, Faylsafe, Golden Gallon, IntelllCheck, Intellitrol, Mark IV, Sculclamp, Sculflow, Sculmatic, Twis-Lok, Unifil, Ventafil, Ventalarm, V.I.P. and Whistler are registered trademarks of Scully Signal Company. All Rights Reserved. Specifications are subject to change without notice.

00000 Rev A
March 2017



Scully Signal Company
70 Industrial Way
Wilmington, MA 01887, USA
800 272 8559 • sales@scully.com

Scully Systems Europe NV
Maanstraat 25
2800 Mechelen, Belgium
+32 (0) 15 56 00 70 • info@scully.be

Scully UK Ltd
Meridian House, Unit 33
37 Road One Winsford Industrial Estate,
Winsford Cheshire CW7 3QG, UK
+44 (0) 1606 553805 • sales@scullyuk.com

